

## LIFTERS T 165 AP



### T 165 AP

Lifter type	Unit	T 165
Article number		T165I495640BBC24
Push force max.	N	800
Pull force max. **	N	400
Max. lengthwise load statical	Nm	200
Max. lengthwise load dynamical	Nm	100
Max. lateral load statical	Nm	200
Max. lateral load dynamical	Nm	100
Speed (without load)	mm/s	25
Lifter version		2-stage
Max. stroke (custom made)**	mm	700
Retracted length (Standard)	mm	640
Stroke (Standard)	mm	495
Length/Stroke calculation	mm	Length= stroke+145
Fixing points inner profile ***		4 x M8
Fixing points outer profile***		4 x M8
Voltage	V/DC	24
Max. power input	W	144
Max. power consumption	A	6
Cable	mm	1200
Plug	Type	Molex Mini Fit Jr.
Cycle duty (S3)	min	1 / 9 (10 %)
Environment temperature	°C	+10 to +40
Protection rate*	IP	up to 54
Isolation class		III
Weight	kg	5,6
Pulse travel length (2-Hall)	mm/signal	0,319
Integrated end switches		Yes

Stroke tolerance (+/- 2mm) and operating speed depending on load and voltage

\*Depends on installation position

\*\*Other retracted length/stroke/pull application on demand

\*\*\* Screws self cutting/forming according to DIN 7500, thread depth min. L= 2,5 x D  
 Controllers and add-on components see accessoires

## LIFTERS T 165 AP

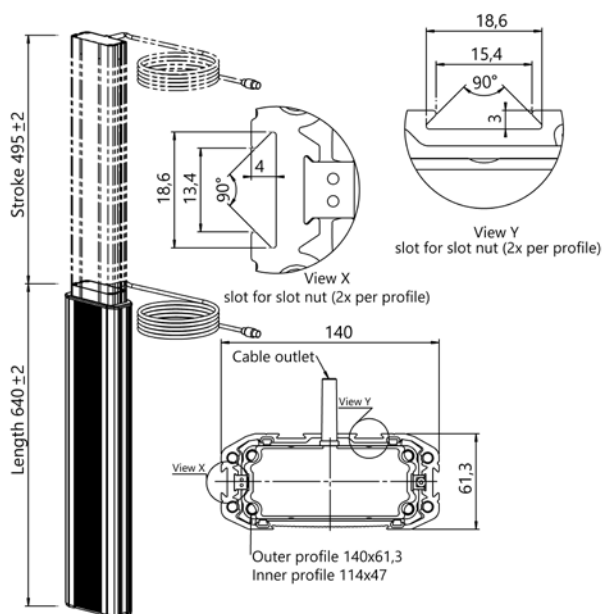

### T 165 AP

